

## Voltage Regulator

**TLE 4317**

### Preliminary Data Sheet

#### Features

- Fixed output voltage regulator 1.8 V, 2.5 V, 3.3 V or 5 V
- Adjustable output down to 1.25 V
- 800 mA output current
- 80 dB ripple rejection
- No output capacitors necessary
- Short circuit protected
- Overtemperature protected

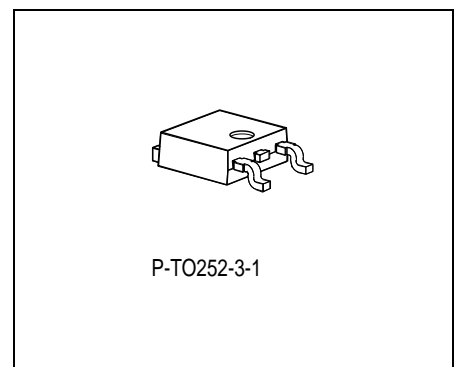
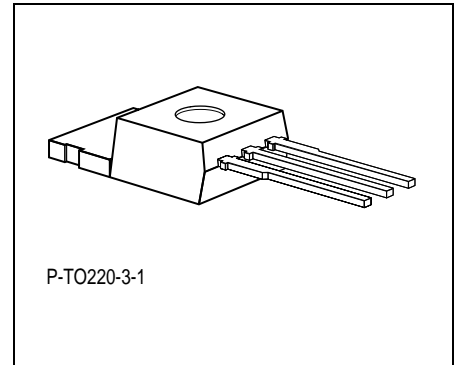

Type	Ordering Code	Package
▼ TLE 4317 V	Q67000-A9475	P-TO220-3-1
▼ TLE 4317 D V	Q67006-A9476	P-TO252-3-1
▼ TLE 4317 D V18	Q67006-A9450	P-TO252-3-1
▼ TLE 4317 D V25	Q67006-A9451	P-TO252-3-1
▼ TLE 4317 D V33	Q67006-A9452	P-TO252-3-1
▼ TLE 4317 D V50	Q67006-A9453	P-TO252-3-1

▼ New device

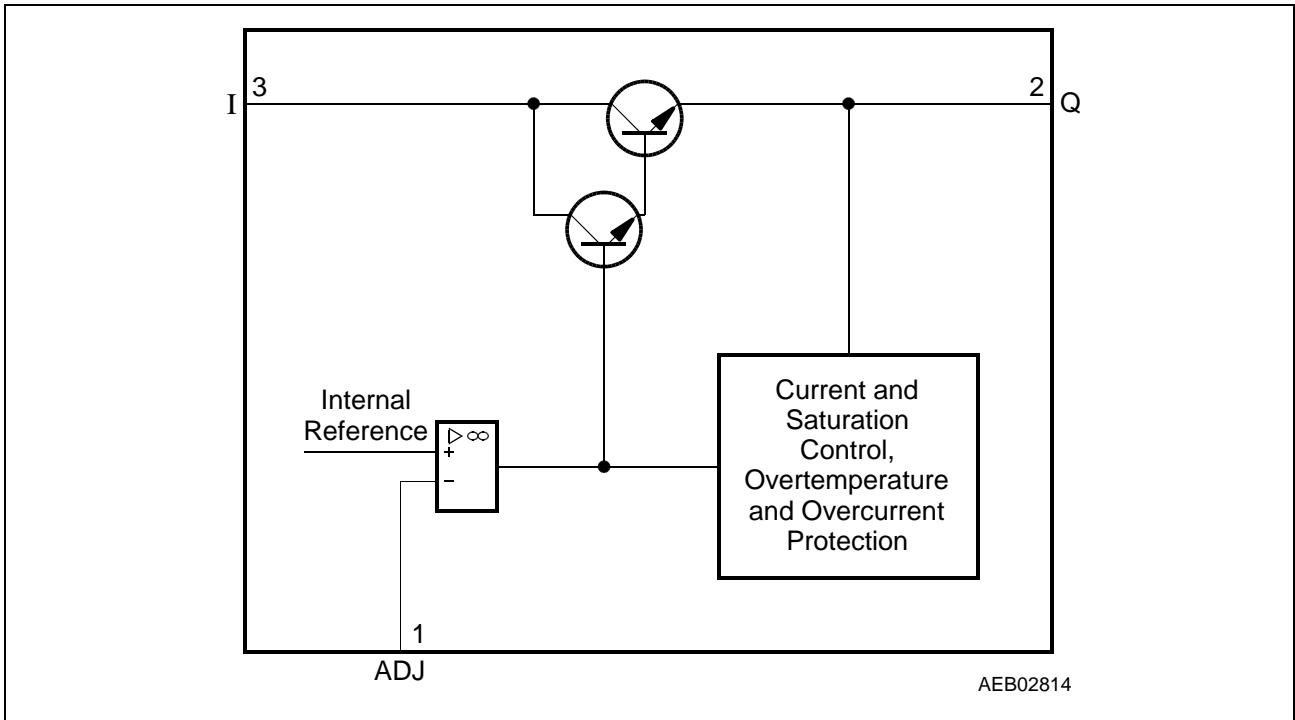

**Figure 1** Block Diagram for Adjustable Output Voltage TLE 4317 V, D V

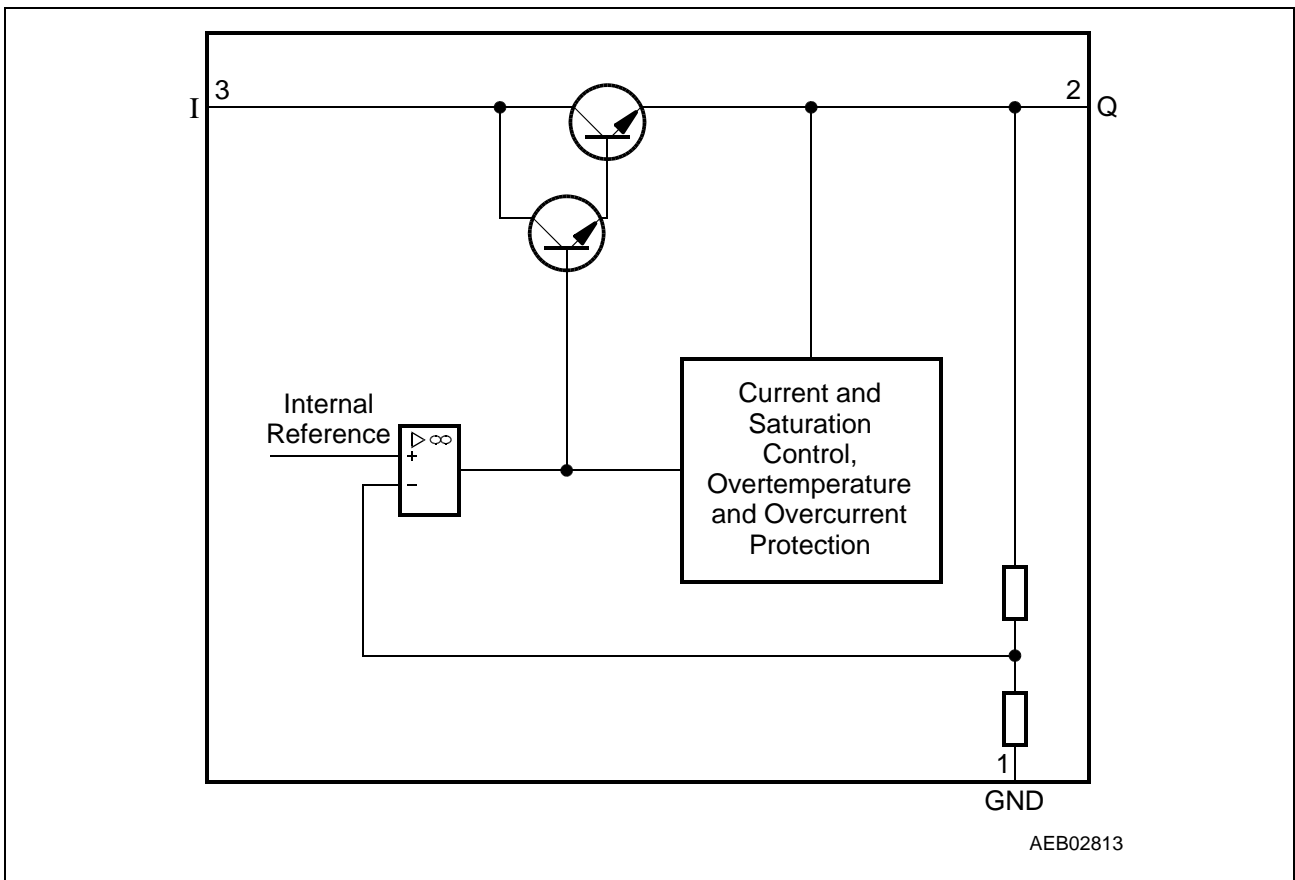

**Figure 2** Block Diagram for Fixed Output Voltage TLE 4317 D V18, 25, 33, 50

### Functional Description

The TLE 4317 is a 3 terminal positive adjustable or fixed voltage regulator. It is capable to supply 800 mA output current. The fixed voltage devices are available for 1.8 V, 2.5 V, 3.3 V and 5 V output voltage. The adjustable device requires 2 external resistors to define an output voltage between 1.25 V and 40 V. The TLE 4317 is packaged either in standard P-TO220-3-1 package or in surface mounted D-Pak package.

The TLE 4317 voltage regulator family offers full overload protection, current limitation, thermal protection and safe operation area protection (SOA).

No external capacitors are needed for the regulator. An input capacitor can be used to filter glitches. An optional output capacitor will improve transient response. Decoupling of the adjust pin at variable voltage regulator can improve the ripple rejection ratios.

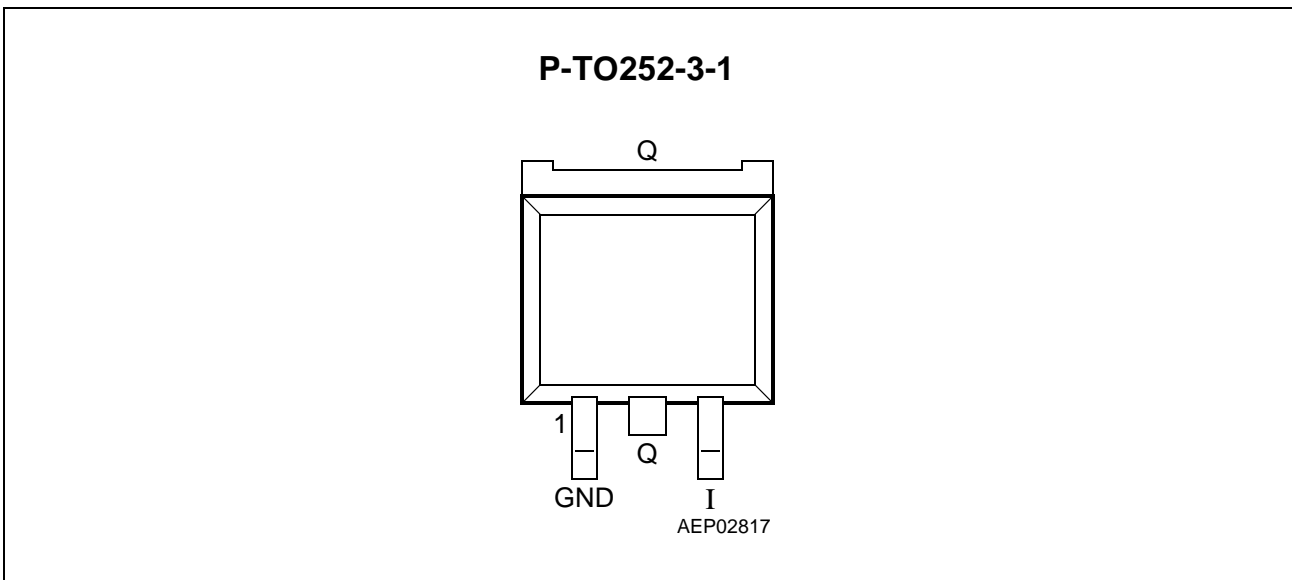

**Figure 3 Pin Configuration (top view)**

### Pin Definitions and Functions TLE 4317 D Vxx Fixed Voltage Devices

Pin No.	Symbol	Function
1	GND	<b>Ground</b>
2	Q	<b>Output;</b> Output voltage is 1.8 V, 2.5 V, 3.3 V or 5 V
3	I	<b>Input</b>

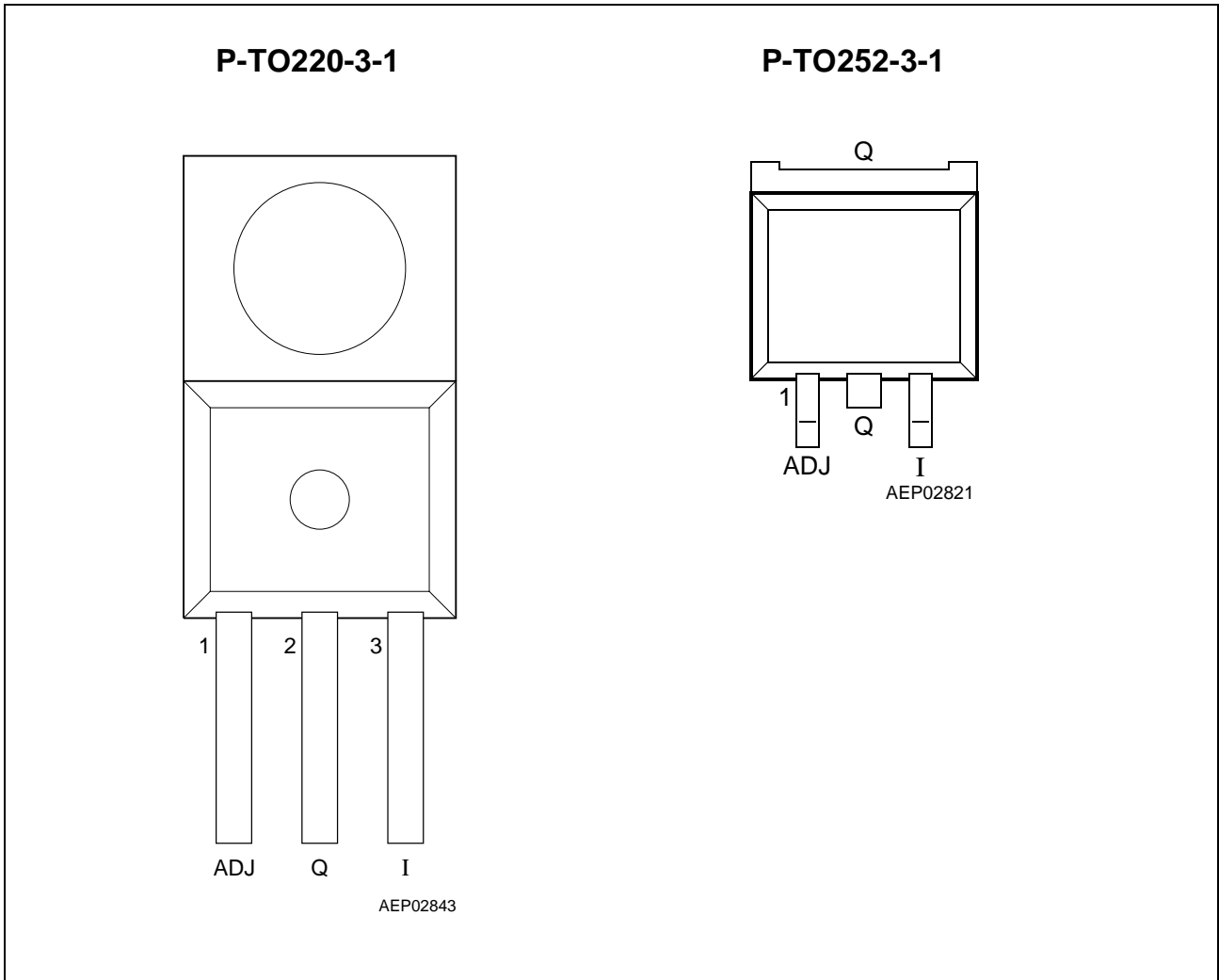

**Figure 4** Pin Configuration (top view)

**Pin Definitions and Functions TLE 4317 V, TLE 4317 D V**

Pin No.	Symbol	Function
1	ADJ	<b>Adjust</b> ; defines output voltage by external voltage divider between Q, ADJ and GND.
2	Q	<b>Output</b>
3	I	<b>Input</b>

**Absolute Maximum Ratings**

Parameter	Symbol	Limit Values		Unit	Test Condition
		min.	max.		

**Voltage Regulator**

**Input - Output Voltage Difference (variable device only)**

Voltage	$V_I - V_Q$	- 0.3	40	V	-
---------	-------------	-------	----	---	---

**Input Voltage (fixed voltage version only)**

Voltage	$V_I$	- 0.3	40	V	-
---------	-------	-------	----	---	---

**Output (fixed voltage version only)**

Voltage	$V_Q$	- 0.3	40	V	-
Current	$I_Q$	-	-	-	Internally limited

**Adjust (variable version only)**

Voltage	$V_{ADJ}$	- 0.3	40	V	-
Current	$I_{ADJ}$	-	-	-	Internally limited

**Ground (fixed voltage version only)**

Current	$I_{GND}$	-	2	mA	-
---------	-----------	---	---	----	---

**Temperature**

Storage temperature	$T_{stg}$	- 50	150	°C	-
Junction temperature	$T_j$	- 40	150	°C	-

*Note: Stresses above those listed here may cause permanent damage to the device. Exposure to absolute maximum rating conditions for extended periods may affect device reliability.*

**Operating Range**

Parameter	Symbol	Limit Values		Unit	Remarks
		min.	max.		
Input Voltage	$V_I$	4.8	40	V	TLE 4317 D V18
Input Voltage	$V_I$	5.5	40	V	TLE 4317 D V25
Input Voltage	$V_I$	6.3	40	V	TLE 4317 D V33
Input Voltage	$V_I$	8.0	40	V	TLE 4317 D V50
Input - Output Voltage Difference	$V_I - V_Q$	3	40	V	TLE 4317 V; TLE 4317 DV
Load Current Range	$I_Q$	10	Internally limited	mA	–
Junction temperature	$T_j$	0	125	°C	–

**Thermal Resistance**

Junction ambient	$R_{thja}$	–	79	K/W	P-TO220-3-1 zero airflow, zero heat sink area
Junction ambient	$R_{thja}$	–	144	K/W	P-TO252-3-1
Junction case	$R_{thjc}$	–	4	K/W	–

*Note: In the operating range, the functions given in the circuit description are fulfilled.*

**Characteristics Adjustable Output Voltage Device TLE 4317 V, D V**
 $0\text{ }^{\circ}\text{C} < T_j < 125\text{ }^{\circ}\text{C}$ ;  $V_1 - V_Q = 5\text{ V}$ ,  $I_Q = 10\text{ mA}$ ; unless otherwise specified

Parameter	Symbol	Limit Values			Unit	Measuring Conditions
		min.	typ.	max.		
Reference voltage	$V_{REF}^{1)}$	1.20	1.25	1.30	V	–
Line regulation	$\Delta V_Q$	–	0.3	1.0	%	$3\text{ V} \leq (V_1 - V_Q) \leq 40\text{ V}$
Load regulation	$\Delta V_Q$	–	0.3	1.5	%	$10\text{ mA} \leq I_Q \leq 800\text{ mA}$ ; $V_1 = 4.25\text{ V}$ ; $V_Q = V_{REF}$
Drop voltage	$V_{DR}$	–	2.1	–	V	$I_Q = 100\text{ mA}^{2)}$
Drop voltage	$V_{DR}$	–	2.15	–	V	$I_Q = 500\text{ mA}^{2)}$
Drop voltage	$V_{DR}$	–	2.2	–	V	$I_Q = 800\text{ mA}^{2)}$
Current consumption; $I_q = I_1 - I_Q$	$I_q$	–	100	120	$\mu\text{A}$	$I_Q = 10\text{ mA}$
Adjust current	$I_{ADJ}$	–	100	120	$\mu\text{A}$	$I_Q = 10\text{ mA}$
Adjust current change	$\Delta I_{ADJ}$	–	$\pm 0.2$	$\pm 1$	$\mu\text{A}$	$10\text{ mA} \leq I_Q \leq 800\text{ mA}$ ; $3\text{ V} \leq (V_1 - V_Q) \leq 20\text{ V}$
Adjust current change	$\Delta I_{ADJ}$	–	$\pm 0.2$	$\pm 1$	$\mu\text{A}$	$10\text{ mA} \leq I_Q \leq 200\text{ mA}$ ; $3\text{ V} \leq (V_1 - V_Q) \leq 40\text{ V}$
Temperature stability	–	–	1	–	%	<sup>3)</sup>
Minimum load current	$I_Q$	–	3.5	10	mA	$V_1 - V_Q = 40\text{ V}$
Current limit	$I_{Qmax}$	1000	–	2200	mA	$V_1 = 13.5\text{ V}$
Current limit	$I_{Qmax}$	50	200	–	mA	$V_1 - V_Q = 40\text{ V}$ ; $T_j = 25\text{ }^{\circ}\text{C}$
RMS Output Noise	–	–	3	–	ppm	ppm of $V_Q$ ; $10\text{ Hz} \leq f \leq 10\text{ kHz}$ ; $T_j = 25\text{ }^{\circ}\text{C}^{3)}$
Power Supply Ripple Rejection	$PSRR$	–	65	–	dB	$V_Q = 10\text{ V}$ , $f_r = 120\text{ Hz}$ , $V_r = 0.5\text{ V}_{PP}$ , $C_{ADJ} = 0\text{ }\mu\text{F}^{3)}$
Power Supply Ripple Rejection	$PSRR$	65	80	–	dB	$V_Q = 10\text{ V}$ , $f_r = 120\text{ Hz}$ , $V_r = 0.5\text{ V}_{PP}$ , $C_{ADJ} = 10\text{ }\mu\text{F}^{3)}$
Long Term Stability	$\Delta V_Q$	–	0.3	1	%	$T_j = 125\text{ }^{\circ}\text{C}$ , $1000\text{ h}^{3)}$

<sup>1)</sup>  $V_{REF} = V_Q - V_{ADJ}$ 
<sup>2)</sup> Drop voltage measured when the output voltage has dropped 100 mV from the nominal value obtained at  $V_Q = V_{REF}$ .

<sup>3)</sup> Guaranteed by design.

**Characteristics 1.8 V Fixed Output Voltage Device TLE 4317 D V18**
 $0\text{ }^{\circ}\text{C} < T_j < 125\text{ }^{\circ}\text{C}$ ;  $V_I = 7\text{ V}$ ,  $I_Q = 10\text{ mA}$ ; unless otherwise specified

Parameter	Symbol	Limit Values			Unit	Measuring Conditions
		min.	typ.	max.		
Output voltage	$V_Q$	1.76	1.8	1.84	V	$T_j = 25\text{ }^{\circ}\text{C}$ , $I_Q = 10\text{ mA}$
Output voltage	$V_Q$	1.73	1.8	1.87	V	$10\text{ mA} \leq I_Q \leq 800\text{ mA}$ ; $4.8\text{ V} \leq V_I \leq 14\text{ V}$
Output voltage	$V_Q$	–	1.8	–	V	$14\text{ V} \leq V_I \leq 40\text{ V}$
Line regulation	$\Delta V_Q$	–	3	10	mV	$4.8\text{ V} \leq V_I \leq 40\text{ V}$
Load regulation	$\Delta V_Q$	–	10	30	mV	$10\text{ mA} \leq I_Q \leq 800\text{ mA}$ ; $T_j = 25\text{ }^{\circ}\text{C}$ ; $V_I = 5\text{ V}$
Drop voltage	$V_{DR}$	–	2.10	–	V	$I_Q = 100\text{ mA}^{1)}$
Drop voltage	$V_{DR}$	–	2.15	–	V	$I_Q = 500\text{ mA}^{1)}$
Drop voltage	$V_{DR}$	–	2.20	–	V	$I_Q = 800\text{ mA}^{1)}$
Current consumption; $I_q = I_I - I_Q$	$I_q$	–	1.1	2.0	mA	$I_Q = 10\text{ mA}$
Temperature stability	–	–	1	–	%	<sup>2)</sup>
Minimum load current	$I_Q$	–	3.5	10	mA	$V_I = 40\text{ V}$
Current limit	$I_{Qmax}$	1000	–	2200	mA	–
Current limit	$I_{Qmax}$	50	200	–	mA	$V_I = 40\text{ V}$ , $T_j = 25\text{ }^{\circ}\text{C}$
RMS Output Noise	–	–	3	–	ppm	ppm of $V_Q$ , $T_j = 25\text{ }^{\circ}\text{C}^{2)}$ $10\text{ Hz} \leq f \leq 10\text{ kHz}$
Supply Voltage Ripple Rejection	$PSRR$	–	65	–	dB	$f_r = 120\text{ Hz}$ , $V_r = 0.5 V_{SS}$ $C_{ADJ} = 0\text{ }\mu\text{F}^{2)}$
Supply Voltage Ripple Rejection	$PSRR$	65	80	–	dB	$f_r = 120\text{ Hz}$ , $V_r = 0.5 V_{SS}$ $C_{ADJ} = 10\text{ }\mu\text{F}^{2)}$
Long Term Stability	$\Delta V_Q$	–	0.3	1	%	$T_j = 125\text{ }^{\circ}\text{C}$ , $1000\text{ h}^{2)}$

<sup>1)</sup> Drop voltage measured when the output voltage has dropped 100 mV from the nominal value obtained at  $V_I = 7\text{ V}$ .

<sup>2)</sup> Guaranteed by design.



**Characteristics 2.5 V Fixed Output Voltage Device TLE 4317 D V25**
 $0\text{ }^{\circ}\text{C} < T_j < 125\text{ }^{\circ}\text{C}$ ;  $V_I = 7\text{ V}$ ,  $I_Q = 10\text{ mA}$ ; unless otherwise specified

Parameter	Symbol	Limit Values			Unit	Measuring Conditions
		min.	typ.	max.		
Output voltage	$V_Q$	2.45	2.5	2.55	V	$T_j = 25\text{ }^{\circ}\text{C}$ , $I_Q = 10\text{ mA}$
Output voltage	$V_Q$	2.43	2.5	2.58	V	$10\text{ mA} \leq I_Q \leq 800\text{ mA}$ ; $5.5\text{ V} \leq V_I \leq 14\text{ V}$
Output voltage	$V_Q$	–	2.5	–	V	$14\text{ V} \leq V_I \leq 40\text{ V}$
Line regulation	$\Delta V_Q$	–	3	10	mV	$5.5\text{ V} \leq V_I \leq 40\text{ V}$
Load regulation	$\Delta V_Q$	–	10	40	mV	$10\text{ mA} \leq I_Q \leq 800\text{ mA}$ ; $T_j = 25\text{ }^{\circ}\text{C}$
Drop voltage	$V_{DR}$	–	2.10	–	V	$I_Q = 100\text{ mA}^1)$
Drop voltage	$V_{DR}$	–	2.15	–	V	$I_Q = 500\text{ mA}^1)$
Drop voltage	$V_{DR}$	–	2.20	–	V	$I_Q = 800\text{ mA}^1)$
Current consumption; $I_q = I_I - I_Q$	$I_q$	–	1.1	2.0	mA	$I_Q = 10\text{ mA}$
Temperature stability	–	–	1	–	%	<sup>2)</sup>
Minimum load current	$I_Q$	–	3.5	10	mA	$V_I = 40\text{ V}$
Current limit	$I_{Qmax}$	1000	–	2200	mA	–
Current limit	$I_{Qmax}$	50	200	–	mA	$V_I = 40\text{ V}$ , $T_j = 25\text{ }^{\circ}\text{C}$
RMS Output Noise	–	–	3	–	ppm	ppm of $V_Q$ , $T_j = 25\text{ }^{\circ}\text{C}^2)$ $10\text{ Hz} \leq f \leq 10\text{ kHz}$
Supply Voltage Ripple Rejection	$PSRR$	–	65	–	dB	$f_r = 120\text{ Hz}$ , $V_r = 0.5 V_{SS}$ $C_{ADJ} = 0\text{ }\mu\text{F}^2)$
Supply Voltage Ripple Rejection	$PSRR$	65	80	–	dB	$f_r = 120\text{ Hz}$ , $V_r = 0.5 V_{SS}$ $C_{ADJ} = 10\text{ }\mu\text{F}^2)$
Long Term Stability	$\Delta V_Q$	–	0.3	1	%	$T_j = 125\text{ }^{\circ}\text{C}$ , $1000\text{ h}^2)$

<sup>1)</sup> Drop voltage measured when the output voltage has dropped 100 mV from the nominal value obtained at  $V_I = 7\text{ V}$ .

<sup>2)</sup> Guaranteed by design.

**Characteristics 3.3 V Fixed Output Voltage Device TLE 4317 D V33**
 $0\text{ }^{\circ}\text{C} < T_j < 125\text{ }^{\circ}\text{C}$ ;  $V_I = 8.5\text{ V}$ ,  $I_Q = 10\text{ mA}$ ; unless otherwise specified.

Parameter	Symbol	Limit Values			Unit	Measuring Conditions
		min.	typ.	max.		
Output voltage	$V_Q$	3.23	3.3	3.37	V	$T_j = 25\text{ }^{\circ}\text{C}$ , $I_Q = 10\text{ mA}$
Output voltage	$V_Q$	3.20	3.3	3.40	V	$10\text{ mA} \leq I_Q \leq 800\text{ mA}$ ; $8\text{ V} \leq V_I \leq 14\text{ V}$
Output voltage	$V_Q$	–	3.3	–	V	$10\text{ mA} \leq I_Q \leq 800\text{ mA}$ ; $14\text{ V} \leq V_I \leq 40\text{ V}$
Line regulation	$\Delta V_Q$	–	3	10	mV	$6.5\text{ V} \leq V_I \leq 40\text{ V}$
Load regulation	$\Delta V_Q$	–	10	50	mV	$10\text{ mA} \leq I_Q \leq 800\text{ mA}$ ; $T_j = 25\text{ }^{\circ}\text{C}$
Drop voltage	$V_{DR}$	–	2.10	–	V	$I_Q = 100\text{ mA}^{1)}$
Drop voltage	$V_{DR}$	–	2.15	–	V	$I_Q = 500\text{ mA}^{1)}$
Drop voltage	$V_{DR}$	–	2.20	–	V	$I_Q = 800\text{ mA}^{1)}$
Current consumption; $I_q = I_I - I_Q$	$I_q$	–	1.1	2.0	mA	$I_Q = 10\text{ mA}$
Temperature stability	–	–	3	–	mV	<sup>2)</sup>
Minimum load current	$I_Q$	–	3.5	10	mA	$V = 40\text{ V}$
Current limit	$I_{Qmax}$	1000	–	2200	mA	–
Current limit	$I_{Qmax}$	50	200	–	mA	$V_I = 40\text{ V}$ , $T_j = 25\text{ }^{\circ}\text{C}$
RMS Output Noise	–	–	3	–	ppm	ppm of $V_Q$ , $T_j = 25\text{ }^{\circ}\text{C}^{2)}$ $10\text{ Hz} \leq f \leq 10\text{ kHz}$
Supply Voltage Ripple Rejection	$PSRR$	–	65	–	dB	$f_r = 120\text{ Hz}$ , $V_r = 0.5\text{ }V_{SS}$ $C_{ADJ} = 0\text{ }\mu\text{F}^{2)}$
Supply Voltage Ripple Rejection	$PSRR$	65	80	–	dB	$f_r = 120\text{ Hz}$ , $V_r = 0.5\text{ }V_{SS}$ $C_{ADJ} = 10\text{ }\mu\text{F}^{2)}$
Long Term Stability	$\Delta V_Q$	–	0.3	1	%	$T_j = 125\text{ }^{\circ}\text{C}$ , $1000\text{ h}^{2)}$

<sup>1)</sup> Drop voltage measured when the output voltage has dropped 100 mV from the nominal value obtained at  $V_I = 8.5\text{ V}$ .

<sup>2)</sup> Guaranteed by design.

**Characteristics 5.0 V Fixed Output Voltage Device TLE 4317 D V50**
 $0\text{ }^{\circ}\text{C} < T_j < 125\text{ }^{\circ}\text{C}$ ;  $V_I = 10\text{ V}$ ,  $I_Q = 10\text{ mA}$ ; unless otherwise specified

Parameter	Symbol	Limit Values			Unit	Measuring Conditions
		min.	typ.	max.		
Output voltage	$V_Q$	4.90	5.0	5.10	V	$T_j = 25\text{ }^{\circ}\text{C}$ , $I_Q = 10\text{ mA}$
Output voltage	$V_Q$	4.85	5.0	5.15	V	$10\text{ mA} \leq I_Q \leq 800\text{ mA}$ ; $8\text{ V} \leq V_I \leq 14\text{ V}$
Output voltage	$V_Q$	–	5.0	–	V	$10\text{ mA} \leq I_Q \leq 800\text{ mA}$ ; $14\text{ V} \leq V_I \leq 40\text{ V}$
Line regulation	$\Delta V_Q$	–	3	10	mV	$8\text{ V} \leq V_I \leq 40\text{ V}$
Load regulation	$\Delta V_Q$	–	10	75	mV	$10\text{ mA} \leq I_Q \leq 800\text{ mA}$ ; $T_j = 25\text{ }^{\circ}\text{C}$
Drop voltage	$V_{DR}$	–	2.10	–	V	$I_Q = 100\text{ mA}^{1)}$
Drop voltage	$V_{DR}$	–	2.15	–	V	$I_Q = 500\text{ mA}^{1)}$
Drop voltage	$V_{DR}$	–	2.20	–	V	$I_Q = 800\text{ mA}^{1)}$
Thermal regulation	–	–	0.04	0.07	%/W	20 ms pulses
Current consumption; $I_q = I_I - I_Q$	$I_q$	–	1.1	2.0	mA	$I_Q = 10\text{ mA}$
Temperature stability	–	–	1	–	%	<sup>2)</sup>
Minimum load current	$I_Q$	–	3.5	10	mA	$V_I = 40\text{ V}$
Current limit	$I_{Qmax}$	1000	–	2200	mA	–
Current limit	$I_{Qmax}$	50	200	–	mA	$V_I = 40\text{ V}$ , $T_j = 25\text{ }^{\circ}\text{C}$
RMS Output Noise	–	–	3	–	ppm	ppm of $V_Q$ , $T_j = 25\text{ }^{\circ}\text{C}^{2)}$ $10\text{ Hz} \leq f \leq 10\text{ kHz}$
Supply Voltage Ripple Rejection	$PSRR$	–	65	–	dB	$f_r = 120\text{ Hz}$ , $V_r = 0.5 V_{SS}$ $C_{ADJ} = 0\text{ }\mu\text{F}^{2)}$
Supply Voltage Ripple Rejection	$PSRR$	65	80	–	dB	$f_r = 120\text{ Hz}$ , $V_r = 0.5 V_{SS}$ $C_{ADJ} = 10\text{ }\mu\text{F}^{2)}$
Long Term Stability	$\Delta V_Q$	–	0.3	1	%	$T_j = 125\text{ }^{\circ}\text{C}$ , $1000\text{ h}^{2)}$

<sup>1)</sup> Drop voltage measured when the output voltage has dropped 100 mV from the nominal value obtained at  $V_I = 10\text{ V}$ .

<sup>2)</sup> Guaranteed by design.

Note: The listed characteristics are ensured over the operating range of the integrated circuit. Typical characteristics specify mean values expected over the production spread. If not otherwise specified, typical characteristics apply at  $T_A = 25^\circ\text{C}$  and the given supply voltage.

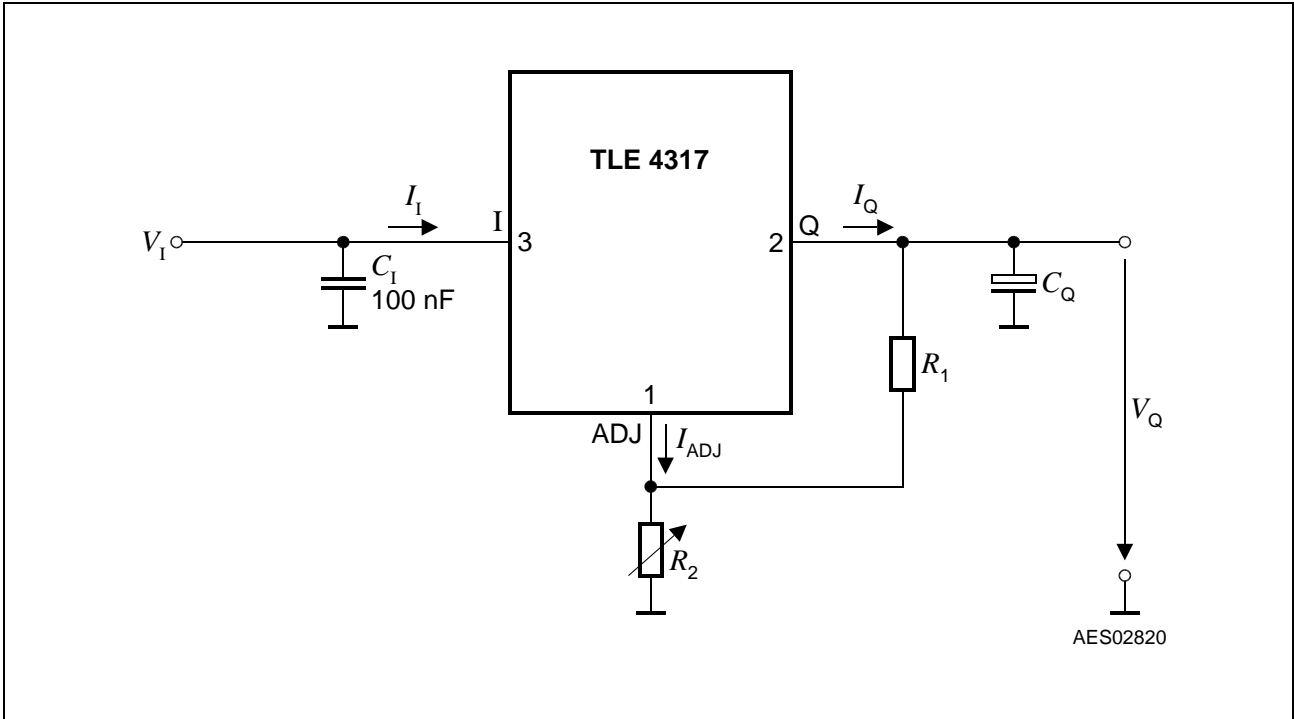

Figure 5 Measuring Circuit Variable Output Voltage TLE 4317 V

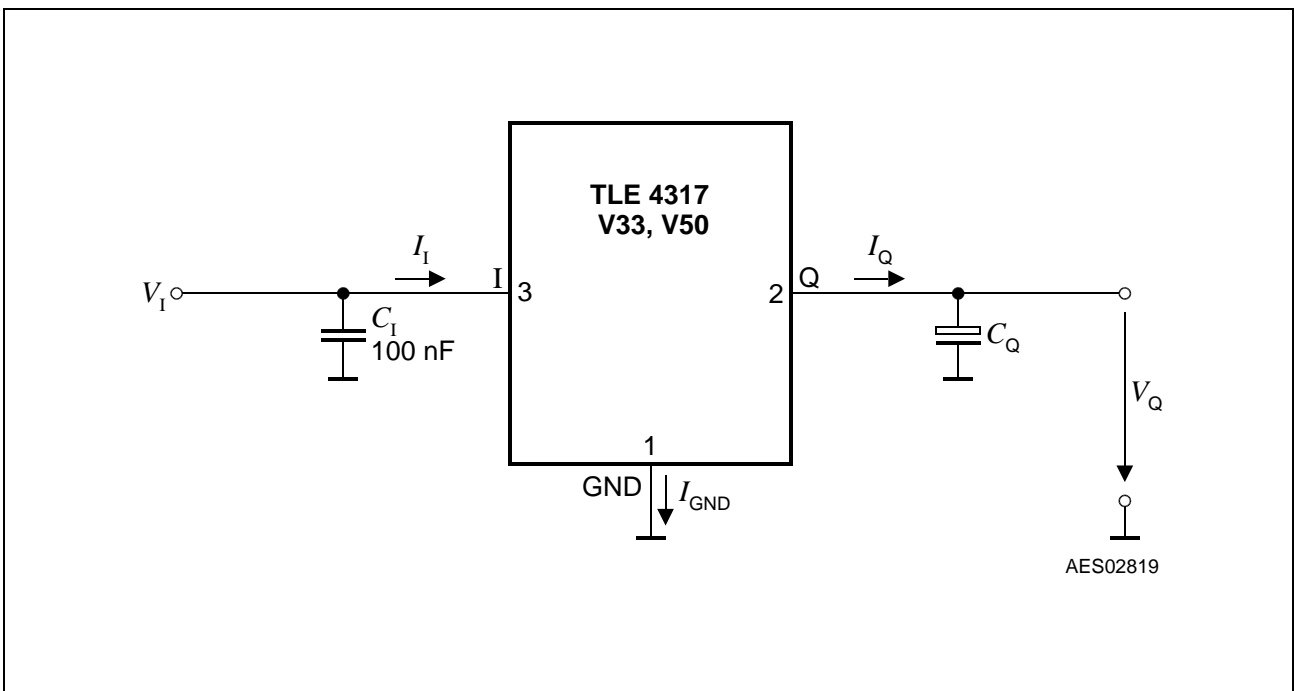
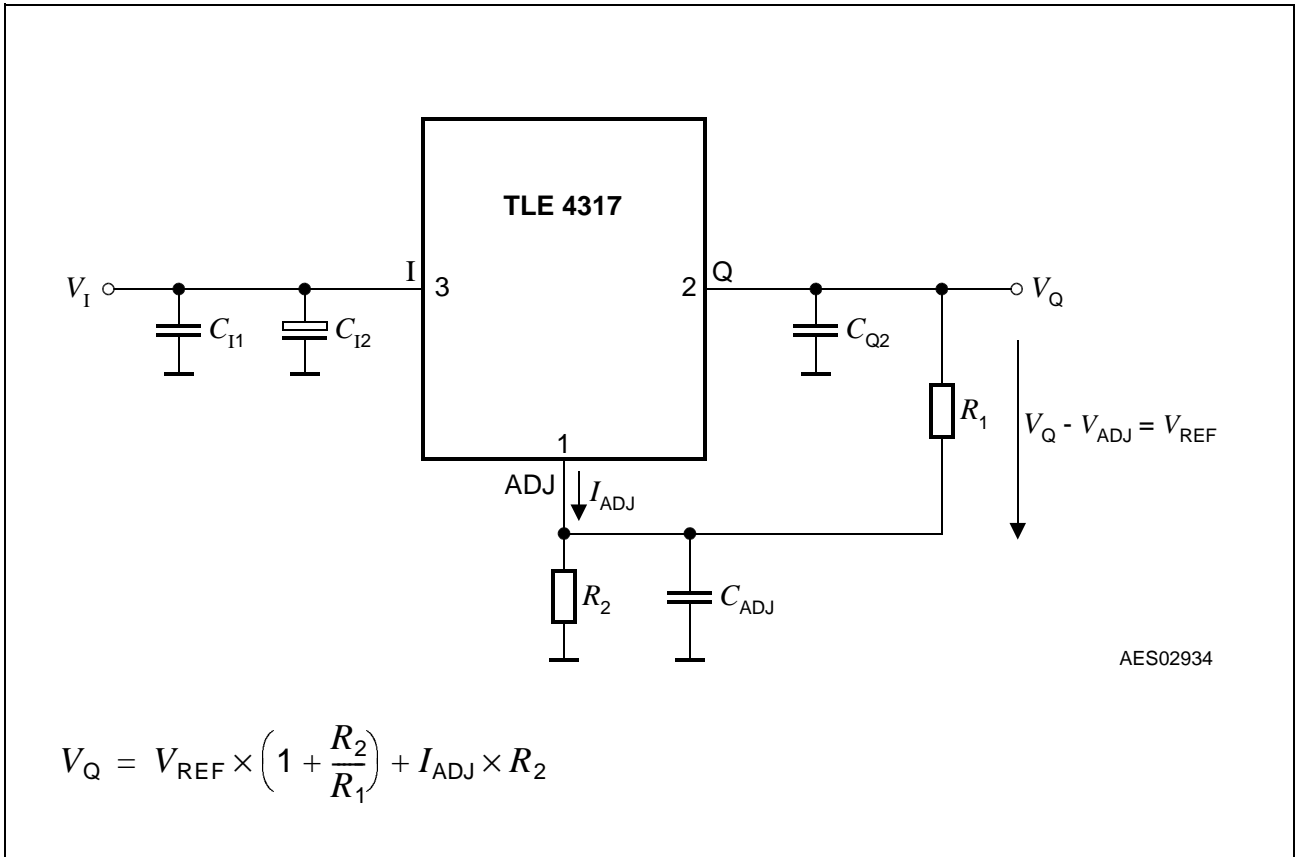
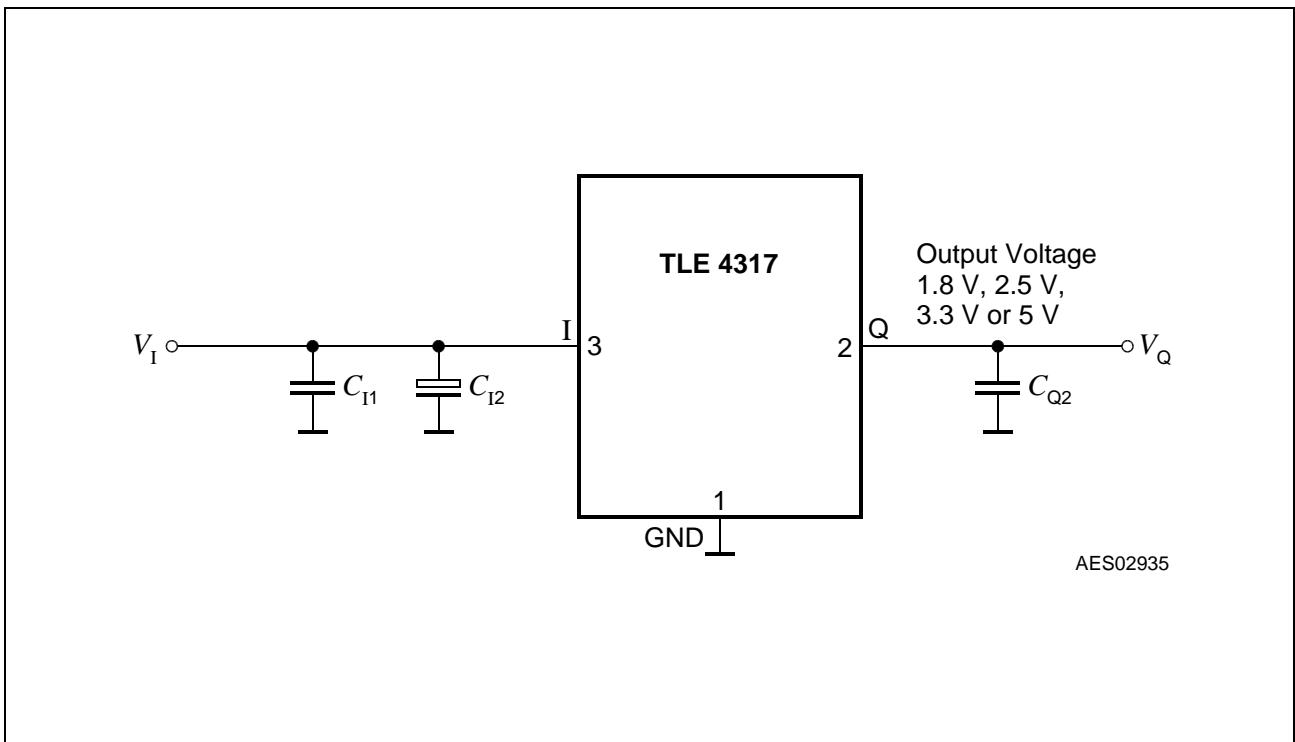

Figure 6 Measuring Circuit Fixed Output Voltage TLE 4317 D V18, 25, 33, 50



**Figure 7 Application Circuit Variable Output Voltage TLE 4317 V**



**Figure 8 Application Circuit Fixed Output Voltage TLE 4317 D V18, 25, 33, 50**

Package Outlines

**P-TO220-3-1**  
(Plastic Transistor Single Outline)

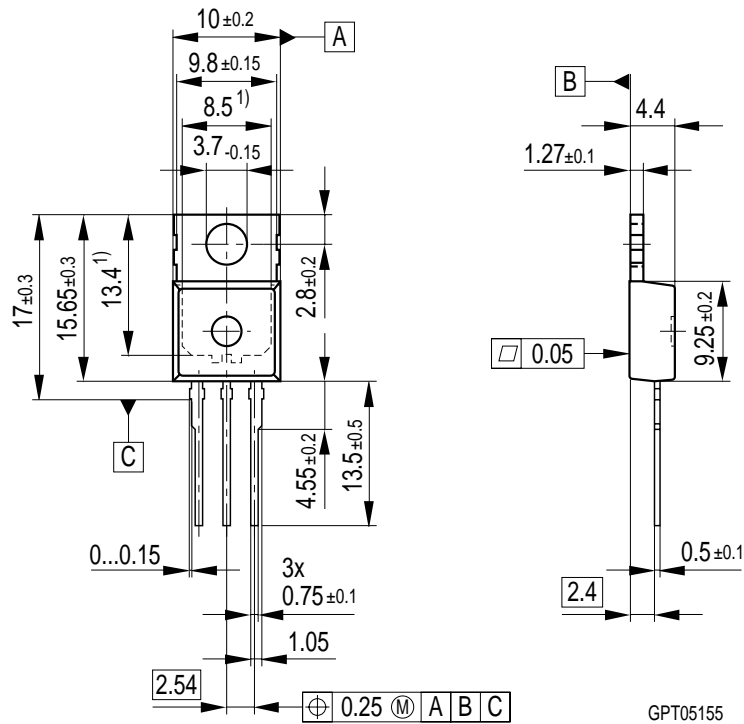

1) Typical  
All metal surfaces tin plated, except area of cut.

**Sorts of Packing**

Package outlines for tubes, trays etc. are contained in our Data Book "Package Information"

Dimensions in mm

**P-TO252-3-1**  
(Plastic Transistor Single Outline)

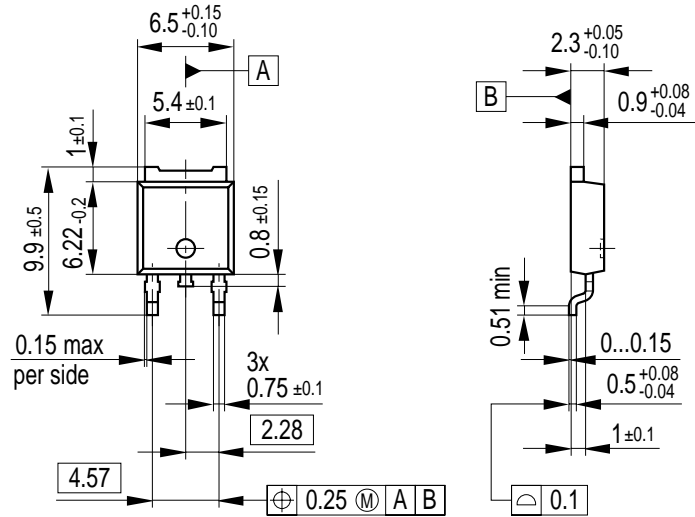

GPT09051

All metal surfaces tin plated, except area of cut.

**Sorts of Packing**

Package outlines for tubes, trays etc. are contained in our Data Book "Package Information"

SMD = Surface Mounted Device

Dimensions in mm

**Edition 2000-08-22**

**Published by Infineon Technologies AG,  
St.-Martin-Strasse 53,  
D-81541 München, Germany**

**© Infineon Technologies AG 2000.  
All Rights Reserved.**

**Attention please!**

The information herein is given to describe certain components and shall not be considered as warranted characteristics.

Terms of delivery and rights to technical change reserved.

We hereby disclaim any and all warranties, including but not limited to warranties of non-infringement, regarding circuits, descriptions and charts stated herein.

Infineon Technologies is an approved CECC manufacturer.

**Information**

For further information on technology, delivery terms and conditions and prices please contact your nearest Infineon Technologies Office in Germany or our Infineon Technologies Representatives worldwide (see address list).

**Warnings**

Due to technical requirements components may contain dangerous substances. For information on the types in question please contact your nearest Infineon Technologies Office.

Infineon Technologies Components may only be used in life-support devices or systems with the express written approval of Infineon Technologies, if a failure of such components can reasonably be expected to cause the failure of that life-support device or system, or to affect the safety or effectiveness of that device or system. Life support devices or systems are intended to be implanted in the human body, or to support and/or maintain and sustain and/or protect human life. If they fail, it is reasonable to assume that the health of the user or other persons may be endangered.